

## 708 Bus Extender Modules

### Description

The 708 Bus Extender Modules allow you to increase the length of wire used to run an LX-Bus™ or keypad bus while providing immunity to noise on the wires. The 708 Bus Extenders ship from the factory as a pair of modules that connect between the panel and LX-Bus or keypad bus devices: One is marked *Connect to Panel*, referred to as the **Panel 708** and the other is marked *Connect to Devices*, referred to as the **Devices 708**. Use the 708 Modules in applications such as long wire runs, in noisy environments, or where the bus run is bundled with other wires, such as telephone company wire.

**Note:** DMP does not recommend running LX-Bus, keypad bus, or 708 bus wires underground due to the possibility of high voltage damage from lightning strikes.

### Installation

Rugged plastic enclosures house the 708 Bus Extender Modules and can be surface-mounted to a wall or other flat surface using the mounting holes provided in the base. After securing the 708 Module to the surface, place the snap-on cover on the plastic housing front.

You may also mount the 708 Module in a DMP enclosure using the standard three-hole pattern.

1. Mount the plastic standoffs to the enclosure using the three included Phillips head screws.
2. Insert the screws from the outside of the enclosure through the holes and into the plastic standoff which mounts on the inside of the enclosure and tighten.
3. After the securing the standoffs onto the enclosure, snap the 708 onto the standoffs.

### 708 Bus Wiring Example

The 708 Module pair can increase the wire distance by a maximum of 4,000 feet. You can connect the Panel 708 to the panel in the panel enclosure or 2,500 feet away from the panel following the normal specifications for an LX-Bus or keypad bus. See the following section. Then you may run 4,000 feet of wire into the field and connect the Devices 708 Module.

After the Devices 708 Module, you may run up to 2,500 feet with LX-Bus or keypad bus devices following the normal specifications for an LX-Bus or keypad bus wire run. Adding a second pair of 708 Modules can further extend the LX-Bus or keypad bus.

**Note:** No Keypad or LX-Bus device can be connected between the 708 Module pairs. An auxiliary power supply is needed to supply the power to operate devices connected to the LX-Bus or Keypad bus after a Device 708 Module.

### Wiring Specifications and Connections

#### LX-Bus/Keypad Bus Wiring Specifications

Several factors determine the performance characteristics of the DMP LX-Bus™ and keypad bus: the *length* of wire used, the *number* of devices connected, and the *voltage* at each device. When planning an LX-Bus™ and keypad bus installation, keep in mind the following four specifications:

1. DMP recommends using 18 or 22-gauge **unshielded** wire for all keypad and LX-Bus circuits. **Do Not** use twisted pair or shielded wire for LX-Bus and keypad bus data circuits. To maintain auxiliary power integrity when using 22-gauge wire do not exceed 500 feet. When using 18-gauge wire do not exceed 1,000 feet. Install an additional power supply to increase the wire length or add devices.
2. Maximum distance for any one circuit (length of wire) is 2,500 feet regardless of the wire gauge. This distance can be in the form of one long wire run or multiple branches with all wiring totaling no more than 2,500 feet. As wire distance from the panel increases, DC voltage on the wire decreases.
3. Maximum number of devices per 2,500 foot circuit is 40.  
**Note:** Each panel allows a specific number of supervised keypads. Add additional keypads in the unsupervised mode. Refer to the panel installation guide for the specific number of supervised keypads allowed.
4. Maximum voltage drop between the panel (or auxiliary power supply) and any device is 2.0 VDC. If the voltage at any device is less than the required level, add an auxiliary power supply at the end of the circuit. When voltage is too low, the devices cannot operate properly.

Refer to the LX-Bus/Keypad Bus Wiring Application Note (LT-2031) for more information. Also see the 710/710F Module Installation Sheet (LT-0310).



**Remove All Power From the Panel!** Remove all AC and Battery power from the panel before installing or connecting any modules, cards, or wires to the panel.

**Ground Yourself Before Handling the Panel!** Touch any grounded metal, such as the enclosure, before touching the panel to discharge static.

The 708 Bus Extender Modules work as a pair to extend the wire length used to run an LX-Bus or keypad bus. Connect the 708 Bus Extender Modules to the panel and to devices in the field using the 4-wire keypad bus or LX-Bus. You may use 18 to 24 AWG twisted pair, shielded, or straight wire between the two 708 Modules.

**Note:** It is important to connect the Panel 708 to the LX-Bus or keypad bus from the panel and to connect the Devices 708 to devices in the field.

### Wiring the Panel 708 Module

First, connect the Panel 708 Module labeled *Connect to Panel* to the panel keypad bus or LX-Bus while observing the installation warnings on the previous page. When connecting to the panel keypad bus, connect the Panel 708 jumper J2, labeled RED YEL GRN BLK, to panel terminals 7, 8, 9, and 10 respectively. Refer to Figure 1.

**Note:** The 708 should be powered by a full-time power source, not one that could be interrupted by a sensor reset.

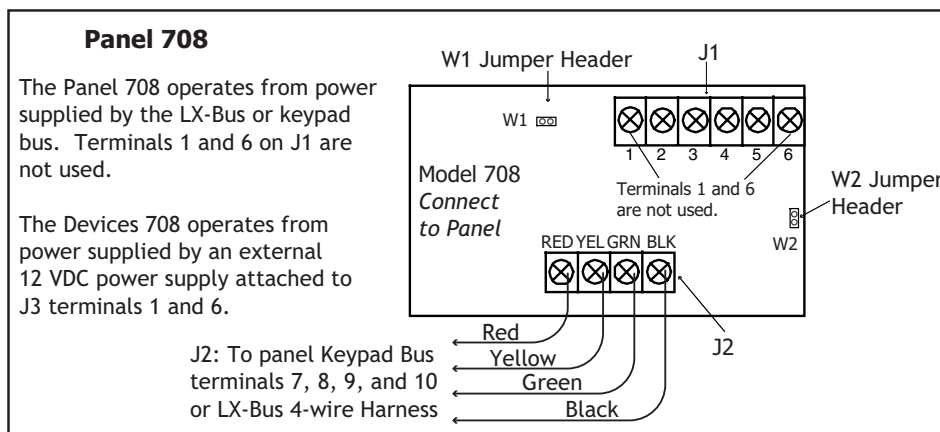

Figure 1: Panel 708 Module Wiring

### Connecting the Two 708 Modules

After connecting the Panel 708, connect the two 708 Modules together using 18 to 24 AWG straight, shielded, or twisted pair wire. Connect J1 on the Panel 708 to J3 on the Devices 708. Connect J1 to J3 by connecting terminal 2 to 2, 3 to 3, 4 to 4, and 5 to 5. When using twisted pair, connect terminals 2 and 3 as a data pair, and 4 and 5 as a data pair. Do not connect terminals 1 or 6 between the two modules. You may install the 708 Modules up to 4,000 feet apart.

**Note:** DMP does not recommend running 708 bus wires underground due to the possibility of high voltage damage from lightning strikes.

**Note:** Do not connect any devices between the two 708 Modules. Connect devices before the Panel 708 module and after the Devices 708 module.

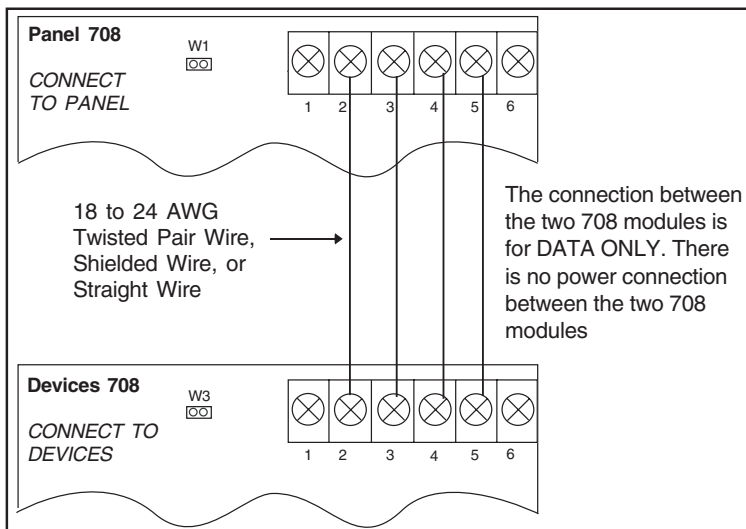

Figure 2: Connecting the two 708 Modules

## Wiring the Devices 708 Module

After connecting the two 708 Modules using terminals 2, 3, 4, and 5, connect the Devices 708 Module labeled *Connect to Devices J3* terminals 1 and 6 to an external power supply. Because no power transfers between the two 708 Modules, an external power supply is needed for the Devices 708 Module. If you do not use an external power supply, the devices connected to the Devices 708 cannot function. Refer to Figure 3 to properly wire the Devices 708 Module to an external 12 VDC power supply such as DMP Model 502-12 or 505-12.

Connect all LX-Bus and keypad bus devices to J4, observing wire colors. The devices connected to the Devices 708 module receive power from the external power supply through the J4 Red and Black terminals.

**Note:** No power is transferred between the two 708 Modules. The Panel 708 module receives power from the panel on the Panel 708 RED and BLK terminals: Therefore terminals 1 and 6 on the Panel 708 terminal J1 are not used. The Devices 708 module requires an external 12 VDC power supply that connects to J3 terminals 1 and 6.

Refer to **LX-Bus/Keypad Bus Wiring Specifications** as needed. Also, refer to the individual device and power supply installation and specifications sheets for more information about wiring devices and power supplies.

**Note:** Do not use shielded wire on LX-Bus devices. Shielded wire can only be used between the two 708 Modules.

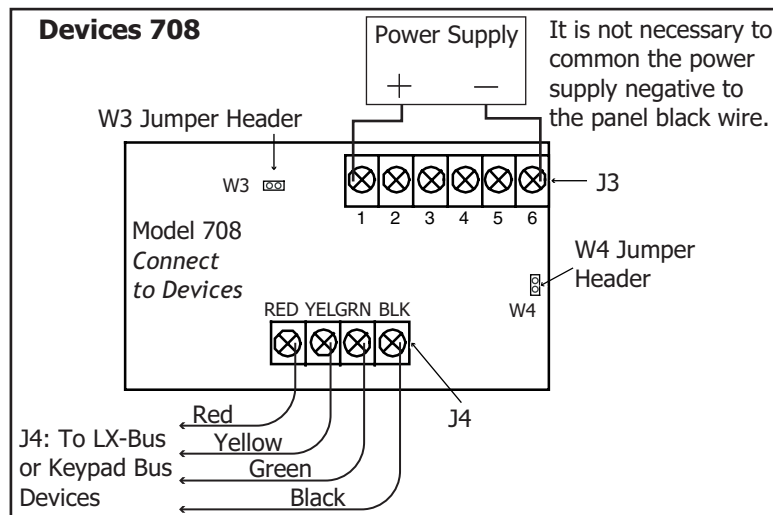

Figure 3: Devices 708 Module Wiring

## Balancing the 708 Bus

Each 708 board has two jumper headers. The jumpers help ensure that the wires between the two 708 Modules are balanced properly for the best communication. Changing the jumper settings can solve communication problems. Refer to Figures 1 and 3 for jumper header locations.

If the Panel 708 is installed on the LX-Bus, run the Diagnostics LX-Bus test to verify proper communication. If a communication problem appears through the LX-Bus test, change the jumper settings as described below. Refer to the XR200 Programming Guide (LT-0196), the XR200-485 Programming Guide (LT-0466), or the XR500 Series Programming Guide (LT-0679) **Diagnostics Function** section for more information about the LX-Bus test.

If the Panel 708 is installed on the keypad bus, check the keypad operation. If the keypad does not function properly, change the jumper settings as described below.

The 708 jumpers come installed from the factory as listed below:

- On the Panel 708 across header W2
- On the Devices 708 across header W4.

If communication errors occur:

- On the Panel 708 install the jumper across W1
- On the Devices 708 install the jumper across W3.

If further errors occur, remove all jumpers from all headers on both 708 modules.

# Wiring Diagram for the 708 Bus Extender Modules

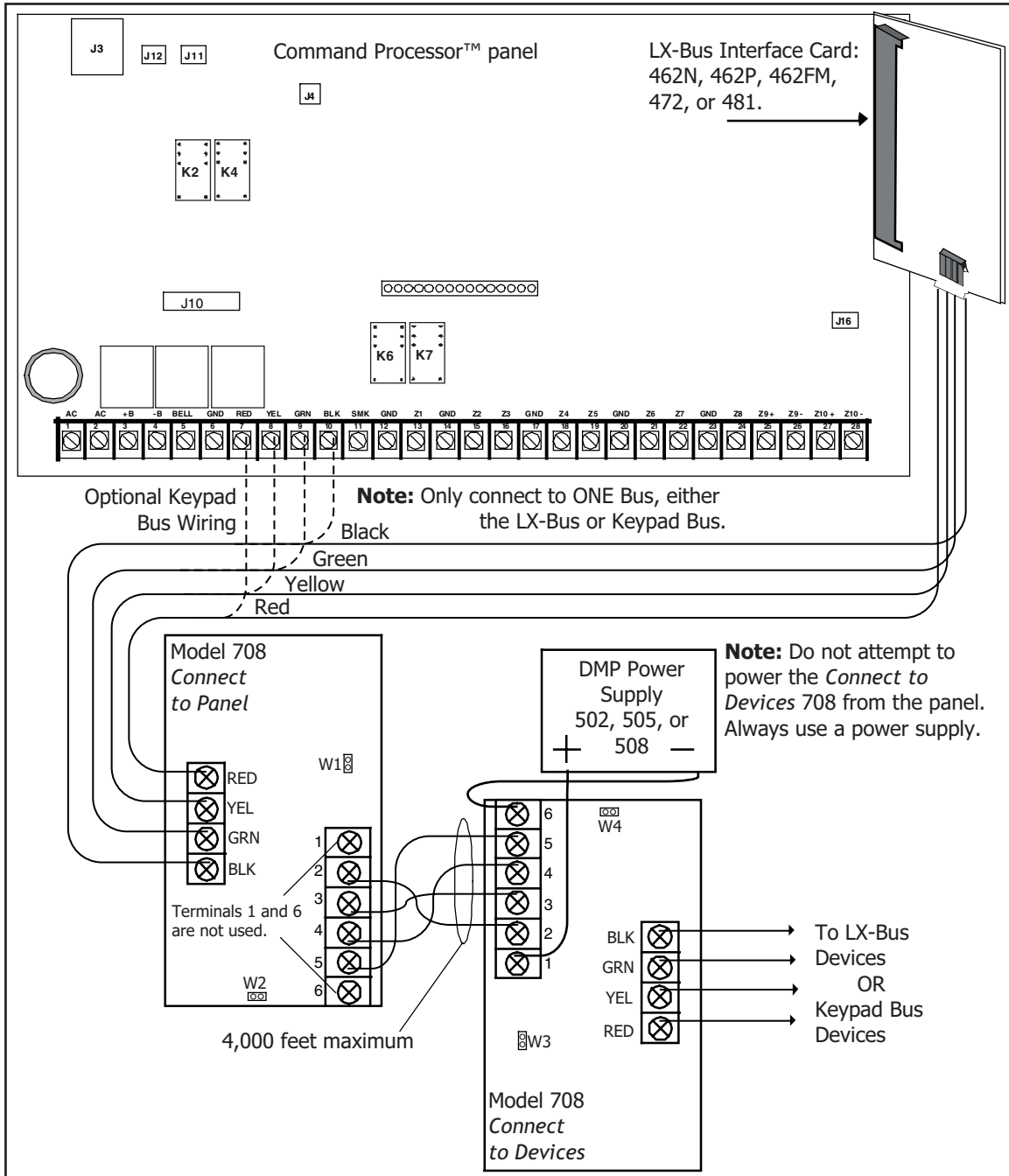

Figure 4: 708 Module Wiring Diagram

<b>708 Specifications</b> Operating Voltage 12 VDC Operating Current <i>Connect to Panel</i> 708 10mA <i>Connect to Devices</i> 708 10mA Maximum Distance Between the two 708 Modules 4,000 Feet	<b>Compatible Panels</b> All DMP Command Processor™ panels  <b>Accessories</b> All DMP LX-Bus and keypad bus devices.